

2008 STANDARD FOR IARI FOR

GRAPHIC AND ELECTRICAL/ ELECTRONIC SYMBOLS FOR

AIR-CONDITIONING AND REFRIGERATING EQUIPMENT

## TABLE OF CONTENTS

### PART PAGE

Section 1. Purpose	3
Section 2. Scope	3
Section 3. Definitions	3
Section 4. Fundamental Items	5
Section 5. Transmission Path	6
Section 6. Contacts, Switches, Contactors, Relays and Solenoids	8
Section 7. Terminals and Connectors	15
Section 8. Transformers, Inductors, Windings	15
Section 9. Semiconductor Devices	16
Section 10 . Circuit Protectors	20
Section 11 . Acoustic Devices	21
Section 12. Lamps and Visual Signaling Devices	22
Section 13. Rotating Machinery	22
Section 14. Voluntary Conformance	24

## STANDARD

### GRAPHIC ELECTRICAL/ELECTRONIC SYMBOLS FOR AIR-CONDITIONING AND REFRIGERATING EQUIPMENT

#### **Section 1. Purpose**

1.1 Purpose. The purpose of this standard is to establish, for air-conditioning and refrigerating equipment, preferred symbols to represent the functions of commonly used electrical and electronic parts in order to facilitate the understanding of electrical wiring diagrams.

1.1.1 This standard is intended for the guidance of the industry, including manufacturers, consulting engineers, distributors, installers, contractors, servicing personnel and other users.

1.2 Review and Amendment. This standard is subject to review and amendment as technology of the industry advances.

#### **Section 2. Scope**

2.1 Scope. This standard applies to all electrical and electronic parts of air-conditioning and refrigerating systems including related accessories and controls.

#### **Section 3. Definitions**

3.1 Graphic Symbols for electrical engineering are shorthand used to show graphically the functioning or interconnections of a circuit. A graphic symbol represents the function of a part in the circuit.\* Graphic symbols are used on schematic or elementary diagrams, or as applicable on connection or wiring diagrams. Graphic Symbols are correlated with parts lists, descriptions, or instructions by means of designations. A symbol shall be considered as the aggregate of all its parts.

3.1.1 IS / IEC Identification. Symbols that have been recommended by the International Electro technical Commission are indicated by IS or IEC.

3.1.2 Applications where shown are examples of preferred combinations of symbols. No attempt has been made to list all possible applications. Additional applications may be devised provided they are a reasonable and intelligible use of other symbols (For application of symbols in electrical diagrams see ANSI Standard Drafting Practices for Electrical and Electronics Diagrams-Y 14.15-1966; Y14.15a-1971 and Y14.15b-1973).

\*For example, when a resistor is employed as a fuse, the fuse symbol is used. For reference designation information, see ANSI/IEEE 200-1975, Reference Designations for Electrical and Electronics Parts and Equipment.

**3.1.2.1 Correlation of Symbol Parts.** For simplification of a diagram, parts of a symbol for a device, such as a relay or contactor, may be separated. If this is done, provide suitable designations to show proper correlation of the parts.

**3.1.2.2 Envelope.** An envelope may be used with a symbol and does not normally indicate evacuation or pressure. However, when used with electron-tube component symbols, the envelope indicates a vacuum enclosure unless otherwise specified.

**3.2 Schematic or Elementary Diagram.** A diagram which shows, by means of graphic symbols, the electrical connections and functions of a specific circuit arrangement. The schematic diagram facilitates tracing the circuit and its functions without regard to the actual physical size, shape, or location of the component device or parts.

**3.3 Orientation.** Except where noted, the orientation of a symbol on a drawing, including a mirror-image presentation, does not alter the meaning of the symbol. Letters and numbers that constitute a part of a symbol shall not be presented in mirror-image form.

**3.4 Line Width.** The width of a line does not affect the meaning of the symbol. In specific cases, a wider line may be used for emphasis.

**3.5 Symbol Size.** A symbol may be drawn to any proportional size that suits a particular drawing, depending on reduction or enlargement anticipated. If essential for purposes of contrast, some symbols may be drawn relatively smaller than the other symbols on a diagram. It is recommended that only two sizes be used on any one diagram.

**3.5.1 Relative Symbol Size.** The symbols shown in this edition of the standard are in their correct relative size. This relationship shall be maintained as nearly as possible on any particular drawing, regardless of the size of the symbol used.







**3.5.2 Arrowheads.** The arrowhead of a symbol may be closed-or open-unless otherwise noted in this standard.





**3.5.3 Angle of Connecting Lines.** In general, the angle at which a connecting line is brought to a graphic symbol has no particular significance unless otherwise noted or shown in this standard.

3.6 Terminal Symbols. The standard symbol for a terminal (0) may be added to each point of attachment of connecting lines to any one of the graphic symbols. Such added terminal symbols should not be considered as part of the individual graphic symbol, unless the terminal symbol is included in the symbol shown in the standard.

3.7 Addition of Supplementary Data. Details of type, impedance, rating, etc., may be added when required, adjacent to any symbol. If used, abbreviations should be from ANSI Y1.1 1972(R1984) Standard Abbreviations for Use on Drawing and in Text. Letter combinations used as parts of graphic symbols are not abbreviations.

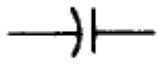
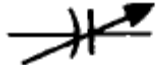
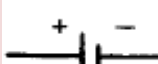
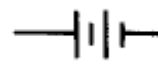

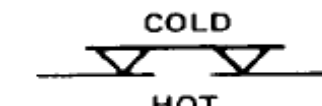



Section 4. Fundamental Items :

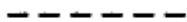

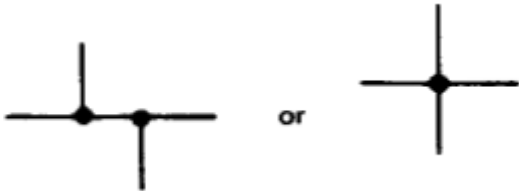
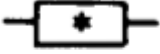

SI.N o.	Item Description	Symbol
4.1	Resistor	
4.1.1	Resistor, General	
4.1.2	Tapped Resistor	
4.1.3	Variable Resistor	
4.1.4	Heating Resistor ( Heater)	
4.2	Thermistor	
4.2.1	General	 Note: The asterisk is not part of the symbol. It means to indicate an appropriate value.
4.2.2	With Independent Integral Heater	
4.3	Capacitor	

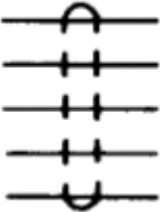
4.3.1	General : If it is necessary to identify the capacitor electrodes, the curved element shall represent the outside electrode	
4.3.2	Variable	
4.4	Battery. The long line is always positive, but polarity may be indicated in addition	
4.4.1	Multi cell	
4.5	Sensing link; fusible link, ambient temperature operated	
4.6	Thermocouple (Dissimilar metals device).	
4.6.1	Temperature Measuring Thermocouple	
4.6.2	Thermopile for pumping heat	
4.7	Spark Gap, Igniter Gap	

**Section 5. Transmission Path**

5.1.	Transmission Path: Conductors, cables, Wiring.	
5.1.1	Factory Wired	
5.1.2	Field Installed or Sales	

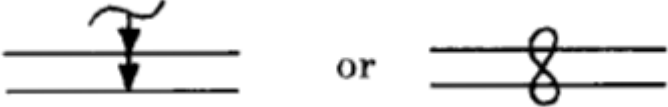
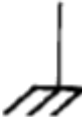

	option, if specified	
<b>5.1.3</b>	Crossing of paths or conductors not Connected. The Crossing is not necessarily at a 90 deg. Angle.	
<b>5.1.4</b>	Junction of paths or conductors	
<b>5.1.4.1</b>	Junction ( Connection)	
<b>5.1.4.2</b>	Application: Junction of connected paths, conductors or wires	
<b>5.1.4.3</b>	<b>Terminal block</b>	 *Terminal number
<b>5.1.5</b>	Assembled Conductors; Cable	
<b>5.1.5.1</b>	Shielded Single Conductor	
<b>5.1.5.2</b>	<b>Shielded Cable ( 5 – Conductor Shown)</b>	
<b>5.1.5.3</b>	<b>Shielded Cable with Shield Grounded ( 2 – Conductor Shown)</b>	

5.1.5.4	<b>Cable ( 2 Conductor Shown)</b>	
5.1.5.5	<b>Ribbon Cable</b>	
5.1.5.6	<b>Twisted Cable (pair, triple etc)</b>	
5.2	<b>Circuit Return</b>	
5.2.1	<p>Ground. (1) A direct conducting connection to the earth or body of water that is a part thereof.</p> <p>(2) A conducting connection to a structure (chassis) that serves a to function similar that of an earth ground (that is, a structure such as a frame of an air, space, or land vehicle that is not conductively connected to earth).</p>	<p style="text-align: center;">Chassis Ground</p>  <p style="text-align: center;">Earth Ground</p> 





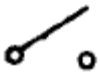
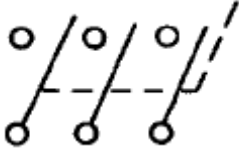
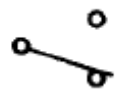
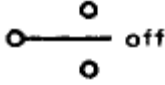
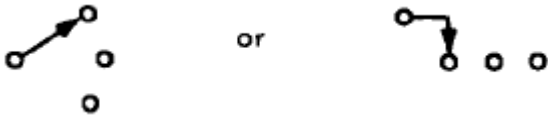

**Section 6: Contacts, Switches, Contactors, Relays and Solenoids**





6.1	<p>Basic Contact Assemblies. The standard method of showing a contact is by a symbol indicating the circuit condition it produces when the actuating device is in the de energized or non operated position. The actuating device may be of a mechanical, electrical, or other nature, and a clarifying note may be necessary with the symbol to explain the proper point at which the contact functions; for example, the point where a contact closes or opens as a function of changing pressure, level, flow, voltage, current, etc. In cases where it is desirable to show contacts in the energized or operated condition and where confusion may result, a clarifying note shall be added to the drawing.</p>
-----	--

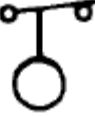



6.1.1	Normally Closed Contact (break).	
6.1.2	Normally Open Contact (make).	
6.2	Operating Coil (Relay coil).	
6.2.1	Solenoid Coil.	
6.3	Switch. Fundamental symbols for contacts, mechanical connections, etc., may be used for switch symbols. The standard method of showing switches is in a position with no operating force applied. For switches that may be in any one of two or more positions with no operating force applied and for switches actuated by some mechanical device (as in air-pressure, liquid-level, rate-of-flow, etc. switches), a clarifying note may be necessary to explain the point at which the switch functions.	
6.4	Pushbutton, Momentary or Spring-Return.	
6.4.1	Normally open, Circuit closing (make).	
6.4.2	Normally closed, Circuit opening (break).	
6.4.3	Two-circuit (dual).	
6.5	Two Circuit, Maintained or Not Spring-Return.	
6.6	Maintained	

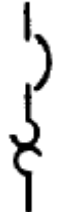
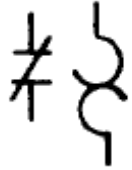

	(Locking) Switch.	
6.6.1	Toggle Switch Single Throw.	
6.6.1.1	Application: 3 Pole Disconnect Switch.	
6.6.2	Transfer, 2-Position-Double Throw.	
6.6.3	Transfer 3-Position.	
6.7	Selector or Multi position Switch. The position in which the switch is shown may be indicated by a note or designation of switch position.	
6.7.1	General (for Power or Control Diagrams). Any number of transmission paths may be shown.	
6.7.2	Segmental contact. Rotary Linear	

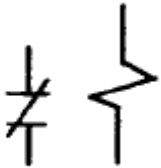
6.7.3	Slide.																								
6.7.4	Master or Control. DETACHED CONTACTS SHOWN ELSEWHERE ON DIAGRAM	<table border="1" style="border-collapse: collapse; text-align: center;"> <thead> <tr> <th rowspan="2">CONTACT</th> <th colspan="3">INDICATOR POSITION</th> </tr> <tr> <th>A</th> <th>B</th> <th>C</th> </tr> </thead> <tbody> <tr> <td>1-2</td> <td></td> <td></td> <td>X</td> </tr> <tr> <td>3-4</td> <td>X</td> <td></td> <td></td> </tr> <tr> <td>5-6</td> <td></td> <td></td> <td>X</td> </tr> <tr> <td>7-8</td> <td>X</td> <td></td> <td></td> </tr> </tbody> </table> <p>X-INDICATES CONTACTS CLOSED</p>	CONTACT	INDICATOR POSITION			A	B	C	1-2			X	3-4	X			5-6			X	7-8	X		
CONTACT	INDICATOR POSITION																								
	A	B	C																						
1-2			X																						
3-4	X																								
5-6			X																						
7-8	X																								
6.8	Limit Switch, Directly Actuated, Spring Returned.																								
6.8.1	Normally Open.																								
6.8.2	Normally Open-Held Closed.																								
6.8.3	Normally Closed.																								
6.8.4	Normally Closed-Held Open.																								
6.9	Switches with Time Delay Feature. NOTE 6.9A: The point of the arrow indicates the direction of switch operation in which contact action is delayed.																								
6.9.1	Normally Open Switch with Time-Delay Closing (NOTC).																								
6.9.2	Normally Closed Switch With Time-Delay Opening (NCTO).																								



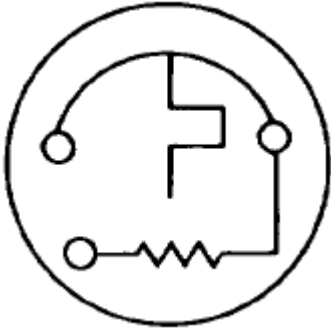

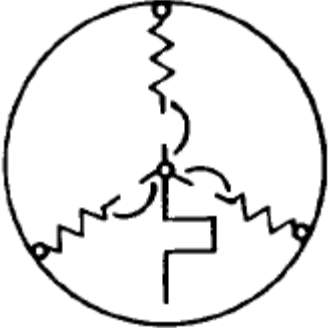
6.9.3	Normally Open Switch With Time-Delay Opening (NOTO).	
6.9.4	Normally Closed Switch With Time-Delay Closing (NCTC).	
6.10	Flow Actuated Switch.	
6.10.1	Closes on Increase In Flow.	
6.10.2	Opens On Increase In Flow.	
6.11	Liquid-Level-Actuated Switch.	
6.11.1	Closes on Rising Level.	
6.11.2	Opens on Rising Level.	
6.12	Pressure- or Vacuum-Actuated Switch.	
6.12.1	Closes on Rising Pressure.	
6.12.2	Opens on Rising Pressure.	

6.12.3	Closes on Rising Differential Pressure.	
6.12.4	Opens on Rising Differential Pressure.	
6.13	Temperature-Actuated Switch.	
6.13.1	Closes on Rising Temperature.	
6.13.2	Opens on Rising Temperature.	
6.14	Overloads (Current).	
6.14.1	Thermal.	
6.14.1.1	Service Trip.	
6.14.1.2	Remote Trip.	
6.14.2	Magnetic.	

6.14.2.1	Series Trip.	
6.14.2.2	Remote Trip.	
6.15	Overload Coils.	
6.15.1	Thermal.	
6.15.2	Magnetic.	
6.15.3	Application: Bi Metallic (Thermal).	
6.15.3.1	No Heater.	
6.15.3.2	With Single Heater (Single Phase).	



6.15.3.3	With Heaters (Three Phase).	
6.16	Humidity Actuated Switch.	
6.16.1	Closes on Rising Humidity.	
6.16.2	Opens on Rising Humidity.	

**Section 7: Connectors**



7.1	Connector, Disconnecting Device. The connector symbol is not an arrowhead. Its larger and the lines are drawn at a 90-degree angle. NOTE 7.1A: Use appropriate number of contact symbols.	
7.1.1	Female Contact.	
7.1.2	Male Contact.	
7.1.3	Separable Connectors (engaged).	
7.1.3.1	Application: Engaged 4-Conductor Connectors: The Plug Has 1 Male and 3 Female Contacts.	

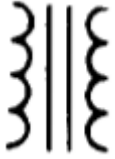
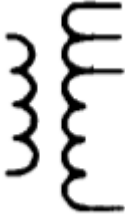





**Section 8: Transformers, Inductors, Windings**









8.1	Transformer	
8.1.1	Current Transformer.	

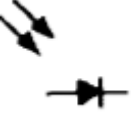



8.1.2	Magnetic core transformer (non-saturating).	
8.1.3	With Taps-1 Phase.	
8.1.4	Autotransformer, 1 Phase.	
8.1.5	Adjustable Autotransformer.	

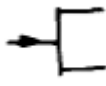
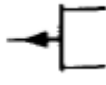
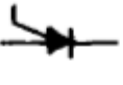
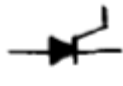
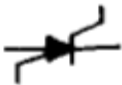

**Section 9: Semiconductor Devices**

9.1	<p>Semiconductor Device, Transistor, Diode.</p> <p>NOTE 9.1A: In general, the angle at which a lead -is brought to a symbol element has no significance.</p> <p>NOTE 9.1B: Orientation, including a mirror-image presentation, does not change the meaning of a symbol. For exceptions to this rule, see 9.3.</p> <p>NOTE 9.1C: The elements of the symbol must be drawn in such an order as to show clearly the operating function of the device.</p>	
9.2	Element Symbols.	
9.2.1	<p>Rectifying Junction or Junction Which Influences a Depletion Layer.</p> <p>Arrowheads  shall be half the length of the -arrow away from the semiconductor base region.</p> <p>The equilateral  triangle shall be filled and shall touch the semiconductor base-region symbol.</p>	

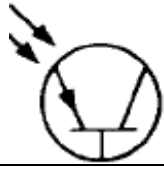
NOTE 9.2.1A:	The triangle points in the direction of the forward (easy) current as indicated by a direct current ammeter, unless otherwise noted adjacent to the symbol. Electron flow is in the opposite direction.	
9.3	Special Property Indicators. See Note 9.1A. If necessary, a special function or property essential for circuit operation shall be indicated by a supplementary symbol included as part of the symbol, as shown in 9.4.	
9.4	Typical Applications: Two-Terminal Devices.	
9.4.1	Semiconductor diode: Semiconductor rectifier diode.	
9.4.2	Breakdown diode; over-voltage absorber.	
9.4.2.1	Unidirectional diode; voltage regulator; Zener diode.	
9.4.2.2	Bi-directional Diode.	
9.4.2.3	Uni directional negative-resistance breakdown diode; trigger diac.	
9.4.2.3.1	NPN-type.	
9.4.2.3.2	PNP-type.	
9.4.2.4	Bio-directional negative resistance breakdown diode; trigger diac.	
9.4.2.4.1	NPN-type.	
9.4.2.4.2	PNP-type.	
9.4.3	Photodiode.	

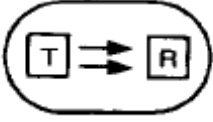
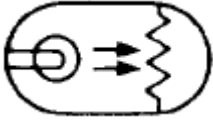
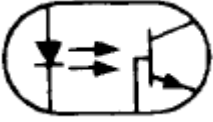
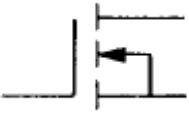
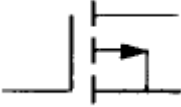

9.4.3.1	Photosensitive type.	
9.4.3.2	Photo emissive type.	
9.4.4	Phototransistor (NPN-type) (without external base-region connection). See also symbol 9.5.11.	
9.5	Typical Applications: Three- (or more) Terminal Devices.	
9.5.1	PNP Transistor (also PNIP transistor, if omitting the intrinsic region will not result in ambiguity). See Note 9.1B.	
9.5.1.1	Application: PNP transistor with one electrode connected to envelope.	
9.5.2	NPN transistor (also NPZN transistor, if omitting the intrinsic region will not result in ambiguity).	
9.5.3	Uni-junction transistor with N-type base.	
9.5.4	Uni-junction transistor with P-type base.	

9.5.5	Field-effect transistor with N-channel junction gate.	
9.5.6	Field-effect transistor with P-channel junction gate.	
9.5.7	Thyristor, reverse-blocking triode-type, N-Type gate; semiconductor controlled rectifier, N-type gate.	
9.5.8	Thyristor, reverse-blocking triode-type, P-type gate; semiconductor controlled rectifier, P-type gate.	
9.5.9	Thyristor, reverse-blocking tetrode-type; semiconductor controlled switch.	
9.5.10	Thyristor, bi directional triode-type; triac; gated switch.	
9.5.11	Phototransistor (PNF-type).	
9.5.12	Photon-Coupled Isolator. Note: T is the transmitter; R is the receiver. The letters are for explanation and are not part of the symbol. Explanatory information should be added to explain circuit operation.	
9.5.12.1	General.	

9.5.12.2	Complete isolator (single-package type).	
9.5.12.2.1	Application: Incandescent lamp and symmetrical photoconductive transducer.	
9.5.12.2.2	Application: Photo emissive diode and phototransistor.	
9.5.13	Field-effect transistor with N-channel MOS gate.	
9.5.14	Field-effect transistor with P-channel MOS gate.	
9.5.15	Thyristor, gate turn-off type.	

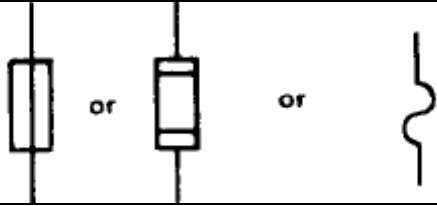
**Section 10: Circuit Protectors**

10.1	Fuse.	
10.1.1	General.	
10.2	Circuit Breaker.	

10.2.1	General.	
10.2.2	Application:3-polecircuitbreakerwith thermal-overload device in all 3 poles.	
10.2.3	Application:3-pole circuit breaker with Magnetic overload load device in all 3 poles.	

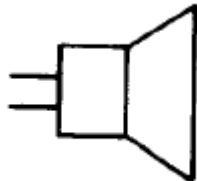

**Section 11: Acoustic Devices**

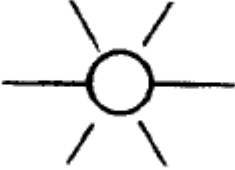
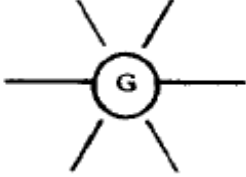

11.1	Audible-Signaling Device.	
11.1.1	Bell, Electrical.	
	NOTE 11.1.1A: If specific identification is required, the abbreviation AC or DC may be added within the square. See Note 11.1.1A	
11.1.2	Horn, Electrical.	

**Section 12: Lamps and Visual Signaling Devices**

12.1	Indicating, pilot, signaling, or switchboard light.		
	<p>NOTE 12.1A: To indicate the characteristic, insert the specified letter or letter sin side the symbol.</p>	<p>A Amber          B Blue          C Clear          F Fluorescent          G Green          NE Neon          O Orange          OP Opalescent          P Purple          R Red          W White          Y Yellow</p>	
12.1.1	Application: green signal light. See Note I2.IA		

**Section 13: Rotating Machinery**

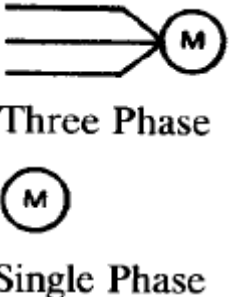
13.1	Rotating Machine.	
13.1.1	Generator (General).	 <p>Three Phase</p>  <p>Single Phase</p>

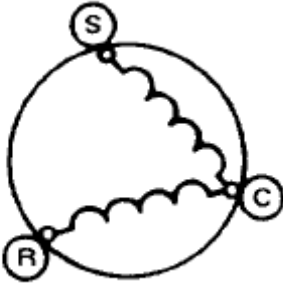
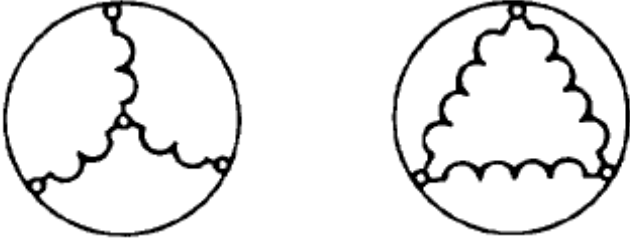
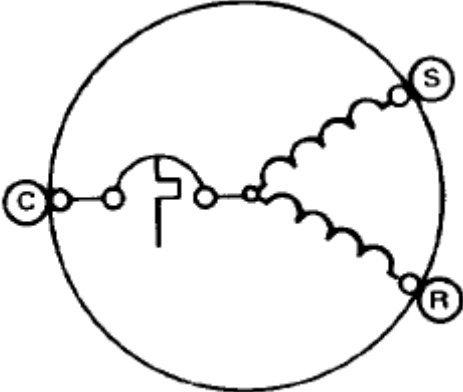
<p>13.1.2</p>	<p>Motor (General).</p>	 <p>Three Phase</p> <p>Single Phase</p>
<p>13.2</p>	<p>Application: Alternating-Current Motors.</p>	
<p>13.2.1</p>	<p>Two lead type.</p>	
<p>13.2.2</p>	<p>External Capacitor Type.</p>	
<p>13.2.3</p>	<p>Poly phase Type.</p>	
<p>13.2.4</p>	<p>Application: Single phase with internal line break protector.</p>	

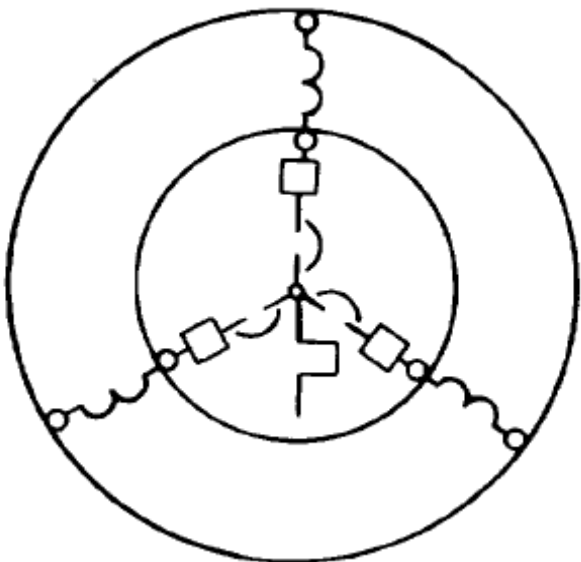
13.2.5	Application: Three-phase with internal line break protector.	 A schematic diagram of a three-phase power system. It features a central star-point neutral connection. Three phase conductors extend from the star point. Each phase conductor contains a square symbol representing a break protector. The conductors are connected to a three-phase load, represented by three circles. The entire system is enclosed within a large outer circle, with a smaller inner circle also centered on the star point.
--------	--	---

**Section 14: Voluntary Conformance**

14.1 Conformance. While conformance with this standard is completely voluntary, symbols represented as being in accordance with this standard shall conform with all the provisions thereof.